

Automatic fuel oil de-aerator comparison



	Automatic fuel oil de-aerators		Automatic fuel oil de-aerators with filter		
Version	Flow-Control 3/K	Flow-Control 3/K HT	FloCo-Top-1K	FloCo-Top-2 KM Si	FloCo-Top-2 Optimum MC-18
Catalogue page	See page 140.	See page 141.	See page 145.	See page 142.	See page 144.
Application area	Single-line systems with return line				
Media	<ul style="list-style-type: none"> Fuel oil EL Diesel fuel Biofuel or bio-diesel with up to 20 % FAME 	<ul style="list-style-type: none"> Fuel oil EL Diesel fuel Biofuel or bio-diesel with up to 100 % FAME Vegetable oils (colza oil) 	<ul style="list-style-type: none"> Fuel oil EL Diesel fuel Biofuel or bio-diesel with up to 20 % FAME 	<ul style="list-style-type: none"> Fuel oil EL Diesel fuel Biofuel or biodiesel with up to 20 % FAME 	
Function	Continuous de-aeration		Continuous de-aeration and oil filtration	Continuous de-aeration and multiple oil filtration	
Filters	-	-	Sintered plastic filter	Sintered plastic filter	Opticlean ultra-fine filters
Vacuum gauge	-	-	-	-0.7/+0.9 bar	
Approval for construction products	Conformity certificate (ÜHP) as per EN 12514-2				

6

i

Nomograph for determining the internal pipe diameter (NW) of the fuel oil suction line in order to keep gas from accumulating in higher pipe sections and sections with downward gradients, or gas formation resulting from excessively high flow speeds.

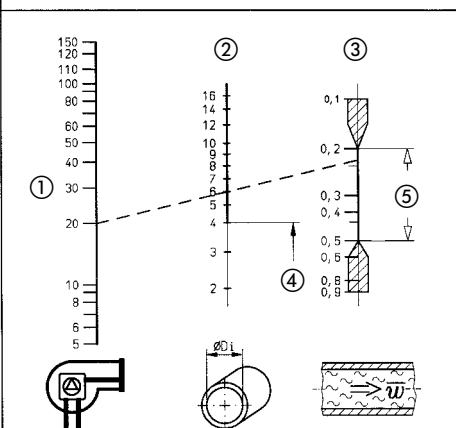

Example: A pipe with $\varnothing 8 \times 1$ mm (NW 6) is required for a volume of 20 l/h and an average flow rate of approx. 0.23 m/s.

Our tip

Only installation by expert companies certified according to the applicable regulations ensures optimum operation of the automatic de-aerators. For optimum combustion, longer nozzle and filter service life and reliable function, the expert determines the following prior to installation and compares the values with the nomograph:

- Oil throughput per hour at burner nozzle
- Inside diameter of the (installed) oil suction line
- Vacuum (overpressure) in the oil carrying pipe upstream of the burner

The oil suction line is often too large. The flow rates of 0.2/0.5 m/s, required according to DIN 4755-2, are often not reached in systems converted from dual-line to single-line mode. The nomograph shows the proper values for sizing the suction line.

- ① Nozzle consumption l/h
- ② Inside diameter of the suction line in mm
- ③ Flow rate of the fuel oil in m/s
- ④ $< \varnothing 4$ not advisable
- ⑤ Recommended range as per DIN 4755-T2

Automatic fuel oil de-aerator

Flow-Control 3/K HT TÜV-tested



- **High temperature version:**
Up to a temperature of the medium of 80 °C
- **Dual float safety system keeps oil foam from escaping**
- **Considerably increased fuel oil filter service life – the amount of filtered oil drawn from the tank corresponds exactly to the oil burnt**
- **No unnoticed leakage in the return line**



Application For single-line systems with return line in oil fired systems for continuous de-aeration. Suitable for the following media: fuel oil EL (DIN 51603-1) and diesel fuel (EN 590) as well as biofuel and biodiesel with up to 100 % FAME as well as vegetable oils (colza oil). Also for use in flood hazard areas. Flow Control 3/K HT is recommended for mounting below the max. fuel oil level in the tank and for any application requiring particular safety.

Description Automatic fuel oil de-aerator consisting of a diecast zinc housing with female G $\frac{1}{4}$ connection thread at the tank end and male G $\frac{3}{8}$ connection threads with 60° cone at the burner end for connection of the burner hoses. An oil hose with ball-shaped sealing for 60° cone and a G $\frac{3}{8}$ union nut is supplied for connection to the fuel oil filter. The de-aerator hood consists of glass-fibre reinforced plastic (not transparent), all seals are made of FKM. Flow-Control 3/K HT features 2 separate float chambers. The lower float chamber contains the operating float; the upper float chamber contains the safety float. The upper float chamber keeps oil foam from escaping via the vent opening (e.g. during commissioning/filter exchange) and also indicates malfunctions of the vent valve. The risk of a leak in the return line going unnoticed is removed with the single-line system. It is no longer necessary to regularly check the return line for leaks. Also suitable for pressure mode up to 0.7 bar. Watertight up to 10 m water column.

Technical specifications

Burner connection

G $\frac{3}{8}$ male with 60° cone for burner hose or G $\frac{1}{4}$ female (part no. 70014)

Tank connection

G $\frac{1}{4}$ female or oil hose G $\frac{1}{4}$ male x G $\frac{3}{8}$
Union nut for connection to filter

Nozzle capacity

Max. 100 l/h

Return flow

Max. 120 l/h

Separating capacity air/gas

Approx. 4 l/h

Mounting position

Float housing vertical to the top

Seals

FKM

Operating temperature range

Medium: Max. 80 °C

Ambient: Max. 60 °C

Operating overpressure

Max. 0.7 bar

(corresponds to static oil column of approx. 8 m)

Test pressure

6 bar

Dimensions

W x H x D: 95 x 147 x 95 mm

Approval

TÜV-tested (S 133 2013 E2)

Approval for construction products

Conformity certificate (ÜHP)

as per EN 12514-2

i

The devices must not be subjected to undiluted additives, alcohol and acids.

DG: G, PG: 1			Part no.	Price €
Flow-Control 3/K HT	1	-	69929	