

Mess-, Regel- und
Überwachungsgeräte
für Haustechnik,
Industrie und Umweltschutz

Lindenstraße 20
74363 Güglingen
Telefon +49 7135 102-0
Service +49 7135-102-211
Telefax +49 7135-102-147
info@afriso.com
www.afriso.com



Operating instructions

Leak detector LAG-14 ER

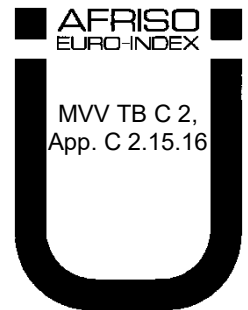

- ☞ Read instructions before using device!
- ☞ Observe all safety information!
- ☞ Keep instructions for future use!



Table of contents

1	This instruction manual	4
1.1	Precautions	4
2	Safety	5
2.1	Intended use.....	5
2.2	Predictable incorrect application	5
2.3	Safe handling	6
2.4	Qualification of personnel	6
2.5	Modifications to the product.....	7
2.6	Usage of spare parts and accessories.....	7
2.7	Liability information	7
3	Product description.....	8
3.1	Application area	10
3.2	Function.....	10
3.3	Operating modes	12
3.4	Application examples	12
4	Technical data	14
4.1	Approvals, tests and conformities	16
5	Transport and storage	17
6	Mounting and commissioning.....	17
6.1	Calculation fundamentals	17
6.2	Installing the container for the leak detection fluid.....	20
6.3	Minimum distance	21
6.4	Pipe installation	22
6.5	Mounting the test valve	24
6.6	Mounting the control unit	24
6.7	Electrical connection	26
6.8	Commissioning the product	30
7	Operation	31
7.1	Alarm condition	31
7.2	Function test.....	32
8	Maintenance	33
8.1	Maintenance times.....	33
8.2	Maintenance activities	33
9	Troubleshooting	34
10	Decommissioning, disposal.....	34
11	Spare parts and accessories.....	36

12	Leak detection fluids for leak detector	37
13	Warranty.....	37
14	Copyright.....	37
15	Customer satisfaction	37
16	Addresses	37
17	Appendix	38
17.1	Certification of specialised company (according to applicable water regulations).....	38
17.2	Approval documents	39
17.3	EU Declaration of Conformity	40
17.4	Declaration of Performance (DoP)	41
17.5	CE Marking.....	42



1 This instruction manual

These operating instructions are part of the product.

- ▶ Read this manual before using the product.
- ▶ Keep this manual during the entire service life of the product and always have it readily available for reference.
- ▶ Always hand this manual over to future owners or users of the product.

1.1 Precautions

WARNING WORD



Type and source of the hazard are shown here.

- ▶ Precautions to take in order to avoid the hazard are shown here.

There are three different levels of warnings:

Warning word	Meaning
DANGER	Immediately imminent danger! Failure to observe the information will result in death or severe injuries.
WARNING	Possibly imminent danger! Failure to observe the information may result in death or severe injuries.
NOTICE	Failure to observe the information may result in damage to property.



2 Safety

2.1 Intended use

The leak detector LAG-14 is a leak detector for liquid-based systems as per EN 13160-1, class II (EN 13160-3).

The LAG-14 ER leak detector may only be used to monitor double-walled containers (tanks) as per chapter 3.1, page 10 containing leak detection fluid in the interstitial space and used for the aboveground storage of:

- Water-polluting liquids
- Flammable liquids with a flash point of $>$ or ≤ 55 °C.

Since July 2003, the LAG-14 ER leak detector may only be used for replacement deliveries for underground, double-walled tanks as a result of the reclassification of water-polluting liquids in Germany.

Leaks in the container (tank) are detected and signalled when the level of the leak detection fluid falls.

Only black containers may be installed in hazardous areas (Ex).

Any use other than the application explicitly permitted in this instruction manual is not permitted.

2.2 Predictable incorrect application

The **control unit** must never be used in the following cases:

- Hazardous area (Ex)
If the product is operated in hazardous areas, sparks may cause deflagrations, fires or explosions.

The intrinsically safe circuit and the corresponding probe may be operated in hazardous areas (EX), zone 0, zone 1 and zone 2.

White containers must not be installed in hazardous areas (Ex).



2.3 Safe handling

The leak detector LAG-14 ER represents state-of-the-art technology and is made according to the pertinent safety regulations. Each product is subjected to a function and safety test prior to shipping.

- ▶ Operate the leak detector LAG-14 ER only when it is in perfect condition. Always observe the operating instructions, all pertinent local and national directives and guidelines as well as the applicable safety regulations and directives concerning the prevention of accidents.

DANGER



Severe burns or death caused by mains voltage (AC 230 V, 50 Hz) in the control unit.

- ▶ Do not expose the control unit to water.
 - ▶ Disconnect the mains voltage supply before opening the control unit or before performing maintenance and cleaning work and make sure it cannot be switched on.
 - ▶ Do not tamper with the control unit in any way whatsoever.
-
- ▶ Observe the instructions in DIN EN 60079-10-1.
 - ▶ Malfunctions which may have an adverse effect on safety must be immediately repaired.

2.4 Qualification of personnel

The product may only be mounted, commissioned, operated, maintained, decommissioned and disposed of by specially qualified companies. These are specialised companies as per § 3 of the German Ordinance on Installations for Handling Water-Polluting Substances April 18, 2017 (German Federal Law Gazette (BGBl.) I p. 377).

These activities do not have to be performed by specialised companies if this obligation does not apply according to the applicable local directives or if AFRISO performs these activities with AFRISO's own, trained staff.

If handling tanks containing liquids with a flash point of $\leq 55^\circ \text{C}$, the staff must also be knowledgeable in fire and explosion protection.

Electrical work may only be performed by trained electricians and in compliance with all applicable local and national directives, regulations and electrical code requirements.



2.5 Modifications to the product

Changes or modifications made to the product by unauthorised persons may lead to malfunctions and are prohibited for safety reasons.

2.6 Usage of spare parts and accessories

Usage of unsuitable spare parts and accessories may cause damage to the product.

- ▶ Use only genuine spare parts and accessories of the manufacturer (see chapter 11, page 36).

2.7 Liability information

The manufacturer shall not be liable in any form whatsoever for direct or consequential damage resulting from failure to observe the technical instructions, guidelines and recommendations.

The manufacturer or the sales company shall not be liable for costs or damages incurred by the user or by third parties in the usage or application of this product, in particular in case of improper use of the product, misuse or malfunction of the connection, malfunction of the product or of connected products. The manufacturer or the sales company shall not be liable for any damage whatsoever resulting from any use other than the use explicitly permitted in this instruction manual.

The manufacturer shall not be liable for misprints.



3 Product description

The leak detector consists of a control unit, a probe and a container for leak detection fluid (black LAG container).

The control unit and the probe are connected by means of a two-wire signal cable with a maximum length of 50 m.

The probe is plugged into the top of the black LAG container. In the case of a leak in the interstitial space, the leak detection fluid level in the black LAG container falls. The electrode rods of the probe are no longer submerged in the leak detection fluid. The control unit detects the change in resistance and generates an alarm.

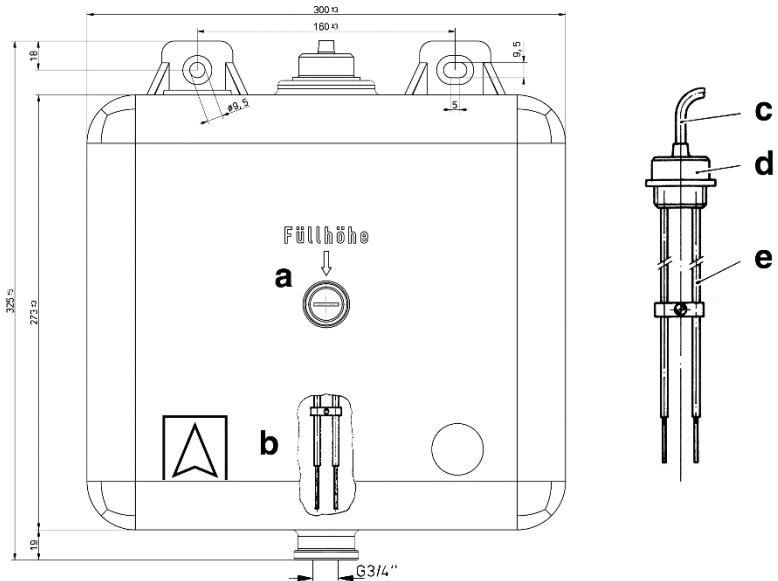

Fig. 1: Container for leak detection fluid (black LAG container) with probe

- | | |
|------------------------------------|-------------------------|
| a Liquid level | d Housing part |
| B Company and approval mark | e Electrode rods |
| c Signal cable | |



Probe

The probe consists of two metallic electrode rods which are installed at a specific distance from each other.

The two electrode rods are contained in a housing with a diameter of 34 mm which also holds the probe in the black LAG container. The probe is equipped with a two-wire signal cable, length 1 m.

Control unit

The control unit SE2 contains the following elements in an impact-resistant plastic housing: display elements and controls as well as all electronic components for signal processing and conversion of the probe signal into a digital output signal.

The output signal is available as a voltage-free relay contact.

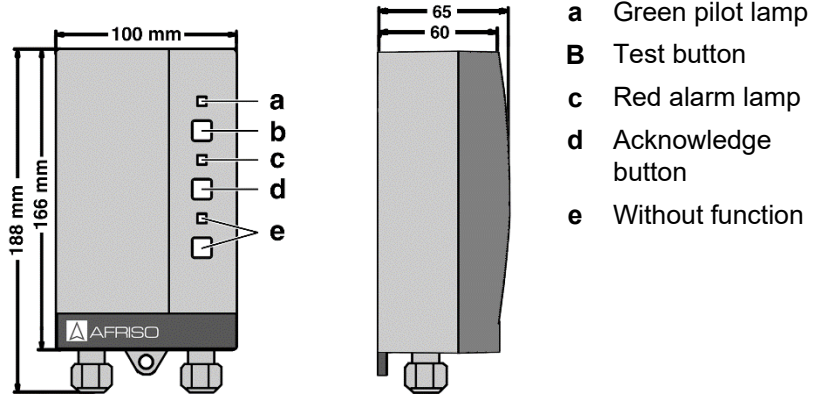

Fig. 2: Control unit



3.1 Application area

Tanks

Only the following tanks are approved: double-walled containers (tanks) which are operated under atmospheric conditions and which comply with the standards DIN 6616 type A, DIN 6623-2, DIN 6624-2, EN 12285-2 (type D) and EN 12285-1 (type D) or which have an approval that the interstitial space is suitable for connection of a liquid-based leak detection system.

The interstitial space volume of the system must not exceed 1 m³.

Stored liquids

Only the following liquids are approved:

- Water-polluting liquids.
- Flammable liquids with a flash point of $> \text{or } \leq 55 \text{ }^\circ\text{C}$.

Approved storage media

If the containers (tanks) are operated under atmospheric conditions and depending on the design of the containers (tanks), water-polluting liquids with the following densities may be stored in the containers (tanks):

- Tanks as per DIN 6616 type A, DIN 6623-2 and DIN 6624-2
 $\leq 2.5 \text{ m } \varnothing$ permissible density $\leq 1.90 \text{ g/cm}^3$
 $\leq 2.9 \text{ m } \varnothing$ permissible density $\leq 1.85 \text{ g/cm}^3$

CAUTION



Danger of reaction of leak detection fluid and stored liquid if unsuitable leak detection fluid is used.

- ▶ The leak detection fluid and the stored liquid may not react. Proven compatibility is required.
 - ▶ Observe the information on the intended use in chapter 2.1, page 5.
-

3.2 Function

The LAG-14 ER leak detector monitors the interstitial space of double-walled tanks filled with leak detection fluid. In the case of a leak in the inner or outer wall of the container (tank), above or below the levels of the stored liquid or the ground water, the leak detection fluid escapes. This causes the level of the leak detection fluid to fall. The electrode rods of the probe are no longer submerged in the leak detection fluid. The control unit detects the change in resistance, generates visual and audible alarms and actuates the output relay.



Probe

The black LAG container is installed above the interstitial space. The bottom side of the black LAG container is connected to the top of the interstitial space via a hose. This way, the black LAG container is the top part of the interstitial space. The interstitial space is filled with leak detection fluid to the middle of the black LAG container. The probe is installed from the top of the black LAG container so that the electrode tips are covered by the leak detection fluid. Both electrodes are connected to the control unit by a two-wire cable.

Control unit

The control unit continuously monitors the electrical resistance between the two electrodes of the probe. The green pilot lamp lights up when the device is ready for operation. If the probe resistance is less than 5 k Ω , there is no alarm condition: The red alarm lamp is off, the relay is:

- De-energised (in the operating mode Eco)
- Energised (in the operating mode FailSafe)

If the resistance is greater than 5 k Ω , an alarm condition, i.e. a leak has been detected by the control unit: The red alarm lamp and the audible alarm are on and the relay is:

- Energised (in the operating mode Eco)
- De-energised (in the operating mode FailSafe)

The audible alarm can be muted with the "Acknowledge" button in the case of an alarm.

No alarm is triggered in case of a power outage. When mains voltage is restored, the product immediately resumes operation. If a leak has occurred in the meantime, this is signalled.

The green pilot lamp lights up as soon as the leak detector is supplied with mains voltage. The Test button allows you to simulate an alarm condition in order to perform a function test.



3.3 Operating modes

Eco:

The LAG-14 ER leak detector is equipped with an output relay to transmit the alarm signal to additional external devices. If no error condition is present, the relay is de-energised; in case of an alarm, the relay is energised.

FailSafe:

The LAG-14 ER leak detector is equipped with an output relay to transmit the alarm signal to additional external devices. If no error condition is present, the relay is -energised; in case of an alarm, the relay is de-energised.

The leak detector LAG-14 ER can be operated with or without additional external devices. External devices include units for audible and visual alarm signal or remote alarm devices, building control systems, etc.

3.4 Application examples

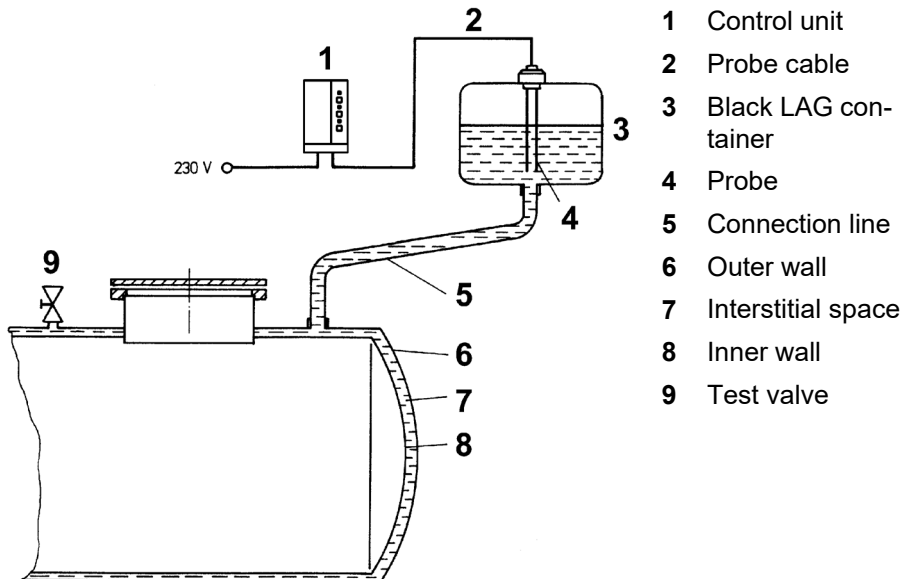

Fig. 3: Standard application

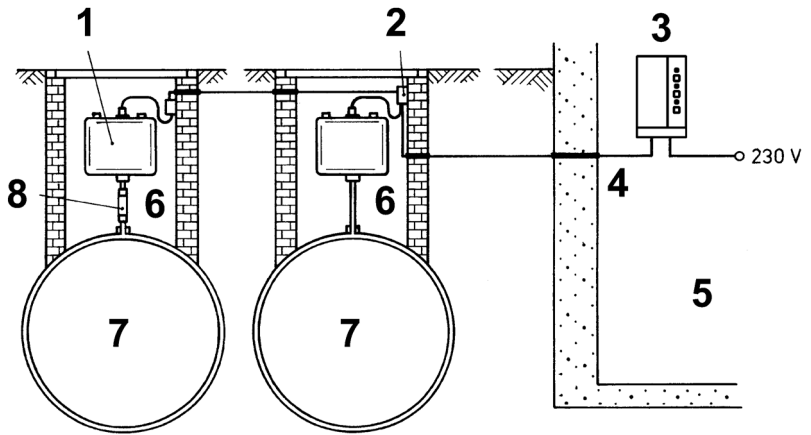

Fig. 4: **Two** black LAG containers at a **single** control unit (different locations)

- | | |
|---|--|
| 1 Black LAG containers, install in recess, if possible | 5 Non-hazardous (safe) area |
| 2 Permanently installed junction boxes, connect both probes in series | 6 Hazardous (Ex) area |
| 3 Control unit | 7 Stored liquid, compatible with leak detection fluids |
| 4 All ducts gastight in protective pipe | 8 Transparent piece, sealed installation |

No more than two black LAG containers with probes may be connected in series to one control unit.



4 Technical data

Table 1: Technical specifications probe and container

Parameter	Value
General specifications	
Dimensions tank (W x H x D)	300 x 325 x 145 mm
Space requirements (W x H x D)	500 x 700 x 200 mm
Weight	1.0 kg
Electrode housing	Plastic, Ø 34 mm
Electrode rods	V 2 A, Ø 3 mm
Resistance	Leak detection fluid
Connection cable:	H05VV-F, 2 x 1 mm ²
Standard length	1 m
Max. length	50 m (shielded)
Container (conductive) black	Hostalen / Vestolen
Surface resistance	< 10 ⁹ Ohm as per DIN 53486
Active volume	4.5 litres (electrode tip to liquid level)
Total volume	10 litres
Connecting hose	EPDM hose 14 x 3 (ID 14)
Operating temperature range	
Ambient	-25 °C to +50 °C, depending on mixing ratio
Storage	-25 °C to +60 °C, depending on mixing ratio
Supply voltage	
Probe voltage	Max. 17 V, AC
Electrical safety	
Degree of protection	IP 20 (EN 60529)



Table 2: Technical specifications control unit SE2

Parameter	Value
General specifications	
Dimensions housing (W x H x D)	100 x 188 x 65 mm
Weight	0.4 kg
Equipment group (2014/34/EU)	II
Category (2014/34/EU)	(1) G
Type of protection	[Ex ia] IIC
Protection class	II
Supply voltage	230 V, 50 Hz
Safety-related maximum voltage U_m	253 V
Degree of protection	IP 30
Response delay	< 1 second
Additional connections	1 output relay (1 changeover contact)
Breaking capacity output relay	Max. 250 V, 2 A, resistive load
Relay fuse	T 2 A
Emissions	The A-weighted sound level of the audible alarm is at least 70 dB(A) at a distance of one metre
Operating temperature range	
Ambient	-20 °C to +50 °C
Supply voltage	
Nominal voltage	AC 230 V \pm 10 %, 50/60 Hz
Nominal power	5 VA
Mains fuse	T 100 mA H (1.5 kA)
Electrical safety	
Protection class	II (EN 60730-1)
Degree of protection	IP 30 (EN 60529)



Electromagnetic compatibility (EMC)	
Emitted interference	EN 60730-1:2011
Noise immunity	EN 60730-1:2011
Probe circuits	
Probe circuit	ia
Maximum values	$U_0 = 16.8 \text{ V}$, $I_k = 57 \text{ mA}$, $P = 240 \text{ mW}$, linear characteristic
for subgroup IIC	$C_0 180 \text{ nF}$; $L_0 1 \text{ mH}$
for subgroup IIB	$C_0 675 \text{ nF}$; $L_0 8 \text{ mH}$
Effective internal capacitance and inductance	Negligible

Cable glands at the control unit

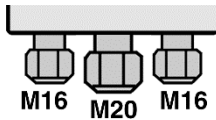

The centre blind piece can be replaced with a cable gland M20.

Cable gland	Cable diameter
M16	4.0 - 8.8 mm
M20	8.0 - 12.5 mm

4.1 Approvals, tests and conformities

LAG-14 ER complies with the EMC Directive (2014/30/EU), the Low Voltage Directive (2014/35/EU), the ATEX Directive (2014/34/EU), the RoHS Directive (2011/65/EU), EC Type Examination Certificate number EX5 11 02 15639 011 and the Construction Products Directive 305/2011 (EN 13160-3:2003).



5 Transport and storage

CAUTION **Damage to the product due to improper transport.**

- ▶ Do not throw or drop the product.
 - ▶ Protect the product from wetness, humidity, dirt and dust.
-

CAUTION **Damage to the product due to improper storage.**

- ▶ Protect the product from shock when storing it.
 - ▶ Store the product packaged in this film.
 - ▶ Store the product in a clean and dry environment.
 - ▶ Protect the product from wetness, humidity, dirt and dust.
 - ▶ Only store the product within the permissible temperature range.
-

6 Mounting and commissioning

6.1 Calculation fundamentals

LAG-14 ER at underground container (tank)

The effective capacity of the black LAG container is limited by the liquid level screw in the centre of the container; it amounts to 4.5 litres. For underground containers (tanks), 1 litre of leak detection fluid is required in the black LAG container per 100 litres of interstitial space volume.

The black LAG container is sufficient for 450 litres of interstitial space volume. This corresponds to containers (tanks) with a storage volume of up to 60,000 litres.

Together with additional containers with an effective capacity of 4.5 litres each, the LAG14 ER leak detector can also be used for tanks with a greater interstitial space volume.

The additional containers are connected to each other and to the black LAG container by means of EPDM hoses.



Leak detection fluid in the interstitial space of the tank as per nameplate on the tank [litres]	Number of required black LAG containers with probe	Number of required additional containers (without probe)
0-450	1	0
450-900	1	1
900-1350	1	2
1350-1800	1	3
1800-2250	1	4

In the case of new installations, the interstitial space volume of the system must not exceed 1000 l.

LAG-14 ER at aboveground container (tank)

For aboveground containers (tanks), 1 litre of leak detection fluid is required in the black LAG container per 35 litres of interstitial space volume.

One black LAG container is sufficient for 157.5 litres of interstitial space volume. This corresponds to containers (tanks) with a storage volume of up to 20,000 litres.

Together with additional containers with an effective capacity of 4.5 litres each, the LAG-14 ER leak detector can also be used for tanks with a greater interstitial space volume.

The additional containers are connected to each other and to the black LAG container by means of EPDM hoses.

Leak detection fluid in the interstitial space of the tank as per nameplate on the tank [litres]	Number of required black LAG containers with probe	Number of required additional containers (without probe)
0-157.5	1	0
157.5-315	1	1
315-472.5	1	2
472.5-630	1	3
630-787.5	1	4

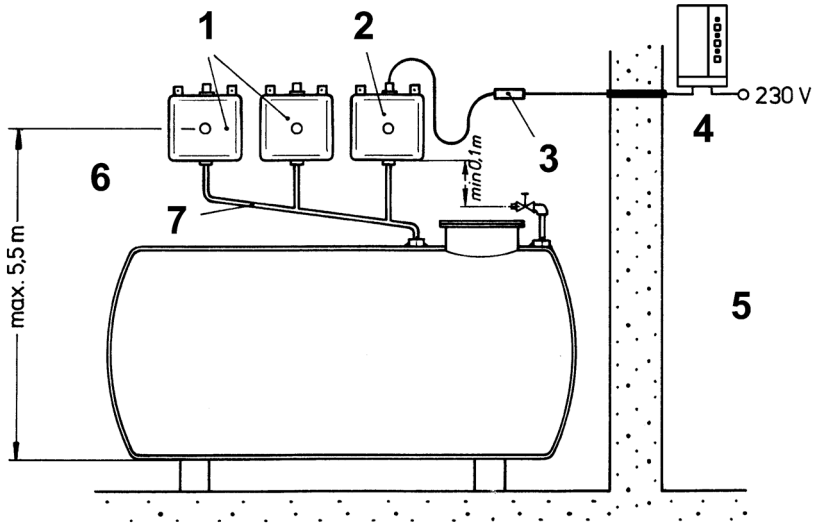

Fig. 5: Additional container

- | | |
|---------------------------------------|--|
| 1 Additional black container | 6 Hazardous (EX) area or non-hazardous (safe) area |
| 2 Black LAG container with probe | 7 Communicating connection |
| 3 Junction box, permanently installed | |
| 4 Control unit | |
| 5 Non-hazardous (safe) area | |

6.2 Installing the container for the leak detection fluid

- ▶ Verify the volume of leak detection fluid required (check the nameplate at the tank (container)) and determine the number of required black LAG containers as described in chapter 6.1, page 17).

The black LAG container can be mounted directly next to the control unit or in the vicinity of the container (tank) to be monitored in hazardous areas (Ex) zone 1 and zone 2 (e.g. in the manhole).

- ▶ When installing the LAG container in the hazardous area (Ex), in the manhole or outdoors, make sure neither surface water no rain nor dirt nor airborne sand can get into the container or into the cable junction box.

- ▶ Mount the black LAG container high enough above the interstitial space for the static pressure of the leak detection fluid to be sufficient at all points of the interstitial space to cause the leak detection fluid to escape and the leak detection fluid level in the black LAG container to fall in the case of a leak so that an alarm can be triggered.

- ▶ The minimum distance between the tank top and the bottom of the black LAG container primarily depends on the density of the stored medium and, in the case of underground tanks, on the possible level of the ground water or backflow above the tank top. Mount the black LAG container at least 30 cm above the tank top.

- ▶ If the test pressure for the interstitial space of the tank is 0.6 bar, the black LAG containers (with reference to the liquid level screw) may be no higher than 5.5 m above the bottom of the tank.

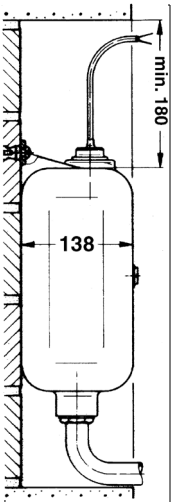



6.3 Minimum distance

The minimum distance between the top of the container (tank) and the black LAG container depends on the density of the stored liquid and is shown in the diagrams below.

$$a_{\min} = D(\rho - 1) + 30 \text{ (cm)}; \quad a_{\max} = 550 - c - D \text{ (cm)}$$

Tank: DIN 6616 type A, DIN 6623-2 and DIN 6624-2

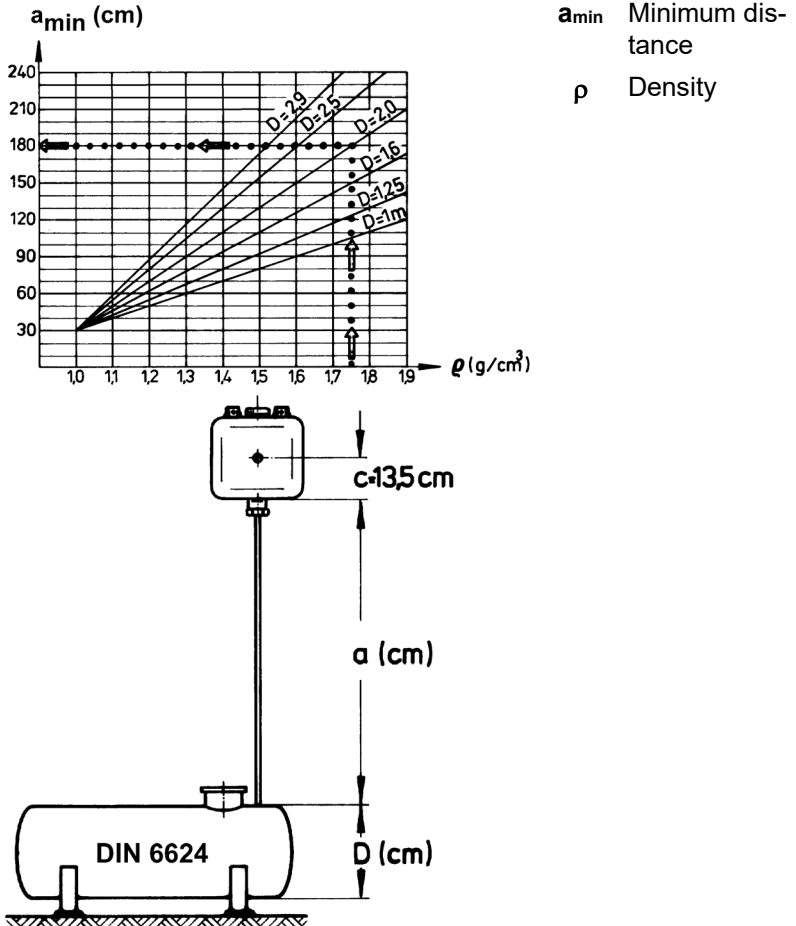

Example: DIN 6624, 60 x 2500; $\rho = 1.7$; $a_{\min} = 175 \text{ cm}$

Tank $\varnothing \leq 2.5 \text{ m}$: Permissible density ≤ 1.9

Tank $\varnothing \leq 2.9 \text{ m}$: Permissible density ≤ 1.85

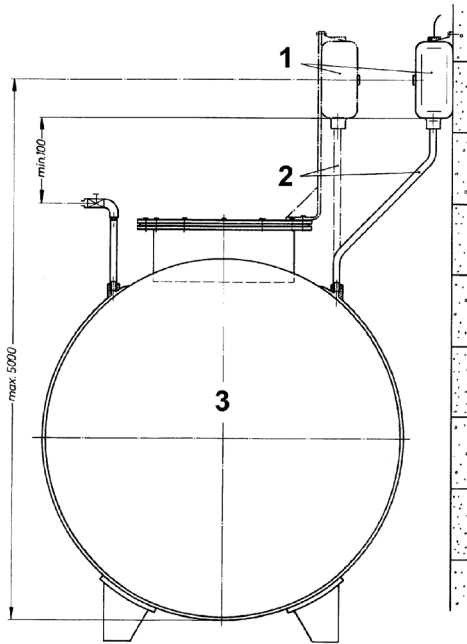

- 1 Black LAG container
- 2 The connection line may not be the only support for the black LAG container
- 3 DIN 6624 double-walled
Stored liquids danger classes A I, A II, A III, B

6.4 Pipe installation

CAUTION



The inside walls of pipes and fittings must not be galvanised since zinc and the approved leak detections fluids form compounds which may cause deposits and lead to clogging.

- ▶ Use only connection pipes and fittings whose inside walls are not galvanised.

The connection between the container (tank) and the black LAG container must have a steady gradient towards the tank; it must not be possible to shut it off. All connections must be tight. The inside walls of pipes and fittings must not be galvanised. The connection line may not be the only support for the black LAG container, even if it consists of steel. Mount the black LAG container to a nearby wall, a cabinet for fittings or to a support made of flat steel or steel brackets in the manhole.

The following types of connections may be used:

- Steel pipes ND 3/4"
With surface protection, inside not galvanised.
Fittings the same. Insulate the outside if the pipes are underground.
- Copper or brass pipe with factory-isolation; install with separate isolating piece upstream of the tank connection.
Inside diameter at least 13 mm. Recommendation: 15 x 1 mm.
- Only hose connections provided by the manufacturer are permissible. The EPDM hose supplied is not petrol-resistant and fuel oil resistant.

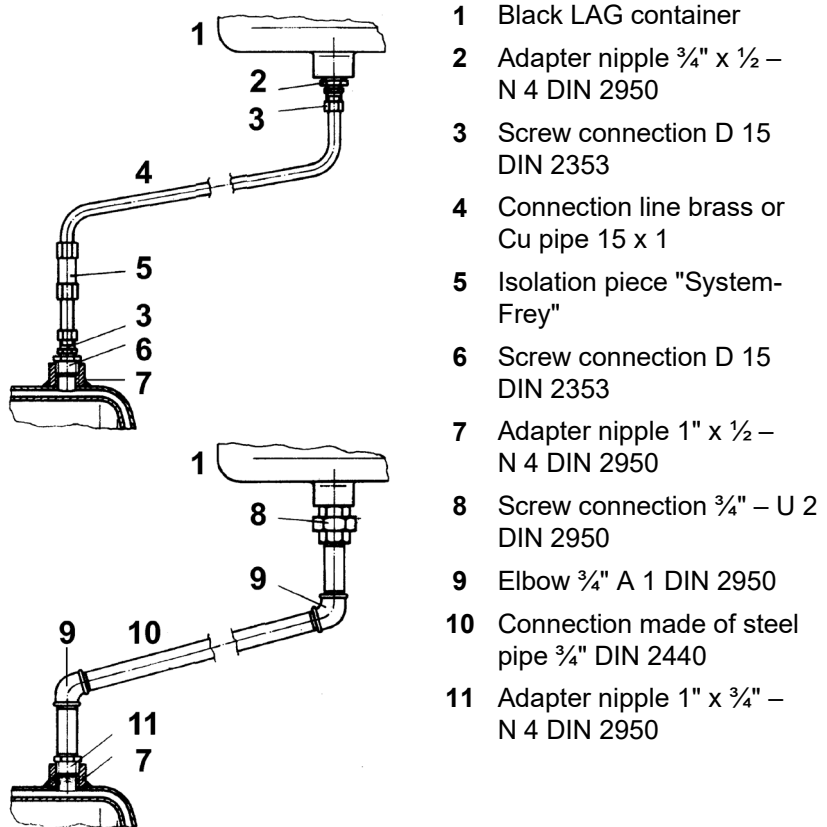

Fig. 6: Installation example LAG piping

Cast fittings and steel connection pipes **not** galvanised inside, but with surface protection on the outside.

6.5 Mounting the test valve

The LAG mounting kit from AFRISO contains a test valve with 1" female thread and a hose connection piece for 12 x 2 mm hoses as well as all other connection parts required for installing the leak detector.

The test valve should be mounted to the connection point opposing connection point of the black LAG container.

Mount the test valve at least 100 mm below the bottom edge of the LAG fluid container at the tank.

There must be sufficient space below the test valve for a container to collect leak detection fluid escaping during the function test.

The leak detection fluid must escape at the test valve with a flow rate of approx. 0.5 l/min during the function test.

6.6 Mounting the control unit

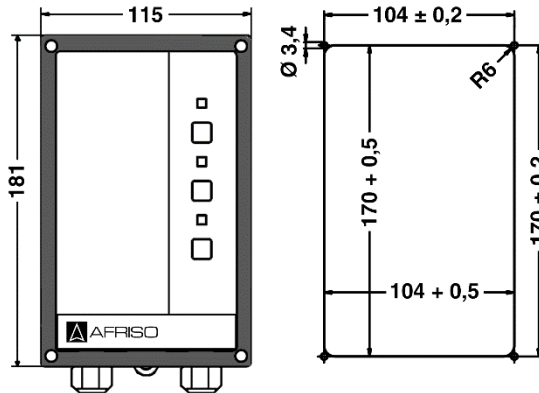
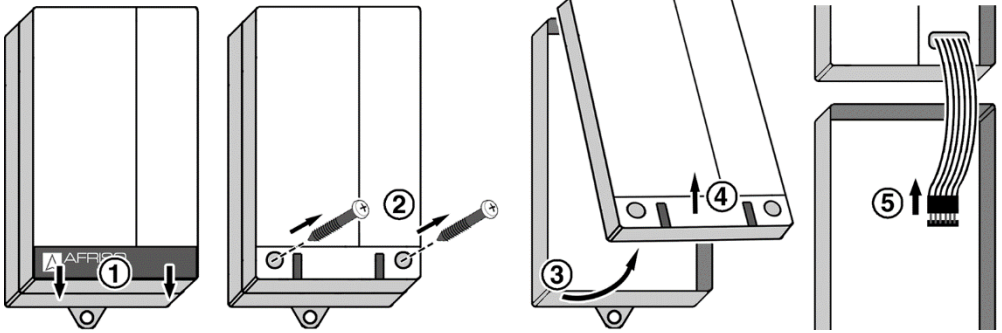

Fig. 7: Control unit with mounting frame for panel mounting; right: control panel cut out

- ☑ Do not install the control unit in hazardous areas (EX areas).
- ☑ Mount the control unit to an even, rigid and dry wall at eye level.
- ☑ The control unit must be accessible and visible at all times.
- ☑ The control unit must not be exposed to water or splash water.
- ☑ The control unit must not be installed in humid rooms.
- ☑ The permissible ambient temperature at the control unit must not be exceeded, see table 2, page 15.
- ☑ Protect the control unit from direct atmospheric influences if it is installed outdoors.



1. Open the control unit.



2. Mount the control unit to the wall.

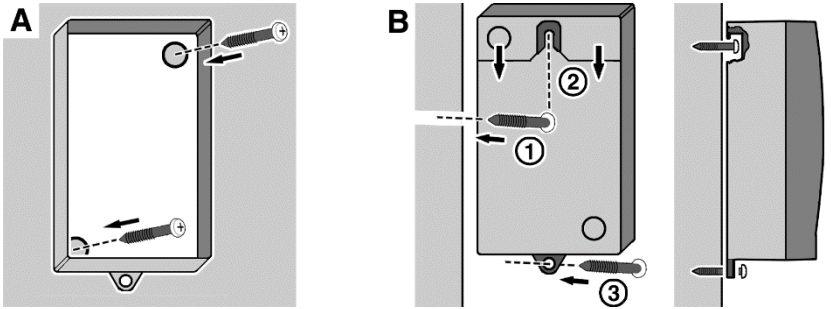

A Drill the fixing holes in the bottom part with a \varnothing 5 mm drill.

Mount the bottom part to the wall with the screws shipped with the unit.

B 1 Mount the screw to the wall.

2 Fit the bottom part.

3 Fixate the bottom part by screwing the bottom lug to the wall.



3. Connect the unit electrically, see chapter 6.7, page 26.
4. Close the control unit.

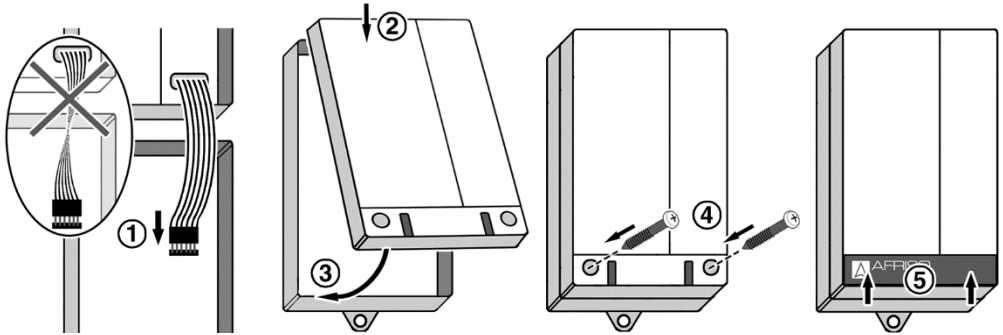

6.7 Electrical connection

- Mains voltage is interrupted and cannot be switched on.

Observe the VDE regulations, the pertinent regulations concerning the prevention of accidents, the operating instructions for the leak detector and the container (tank) as well as all other applicable national and local regulations.

Connect the control unit directly to the 230 V supply mains without a switch and without a plug.

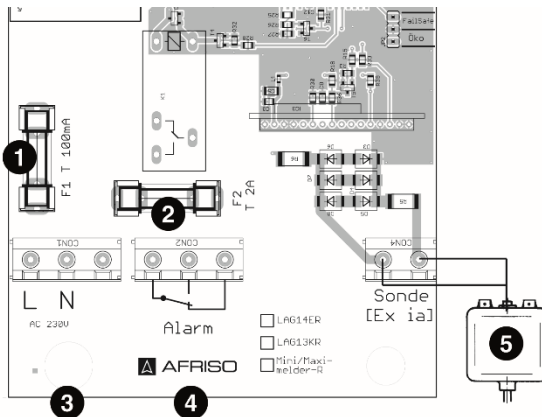

- 1 Mains fuse F1
- 2 Relay fuse F2
- 3 Mains voltage
- 4 Relay for additional alarm
- 5 Probe

Fig. 8: Electrical connection

Supply voltage

Connect the leak detector to mains by means of a permanently installed cable such as NYM-J 3 x 1.5 mm².

1. Route the mains cable through the cable gland at the left into the control unit.
2. Connect the phase to terminal L1 and the neutral conductor to terminal N.
3. Use a separate fuse as per EN 60127-2 for the cable to the control unit (nominal rating 10 A, breaking capacity at least 1.5 kA).

Probe

If the control unit and the black LAG container are mounted next to each other, the signal cable can be directly connected to the control unit. Make sure the probe can easily be removed from the container for the leak detection fluid for function tests. Do not shorten the signal cable.

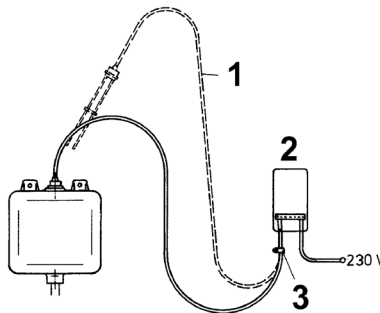

- 1 Do not shorten the signal cable
- 2 Control unit
- 3 Place a cable clamp

Fig. 9: Black LAG container and control unit mounted directly next to each other. Signal cable loose so that the probe can be removed.

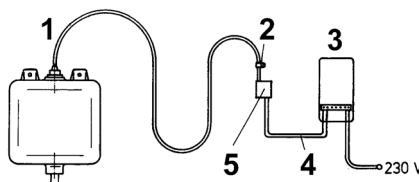

- 1 Do not shorten the signal cable
- 2 Place a cable clamp
- 3 Control unit
- 4 Signal cable extension
- 5 Junction box, permanently installed

Fig. 10: Black LAG container and control unit at different locations. Signal cable loosely connected to the underground cable via a junction box so that the probe can be removed.



In the case of greater distances, mount a cable junction box with degree of protection IP 55 next to the top of the black LAG container. Make sure the probe can easily be removed from the container for the leak detection fluid for function tests. Do not shorten the signal cable.

- ▶ Use control cables with 2 x 1 mm² with blue cable jacket for intrinsically safe current circuits to extend the signal cable. Use shielded cable at lengths of 5 m and more.
- ▶ The total length of the signal cable must not exceed 50 m. Use underground cables such as NYY 2 x 1.5 mm² for underground cable installation.
- ▶ Do not route intrinsically safe circuits and circuits that are not intrinsically safe in the same cable duct. Observe VDE 0165 and all other regulations applicable at the installation site.
- ▶ Do not route the signal cable next to mains cables; danger of interference.
- ▶ Protect the signal cable from damage; use a metal pipe, if required.
- ▶ Route the signal cable from the probe through the left cable gland into the control unit and connect it to the blue two-pole terminal with the designation "Probe" in the control unit. You do not have to ensure a specific polarity.

No more than two black LAG containers with one probe each may be connected in series to one control unit.

Output

The output signal of the leak detector is made available via a voltage-free relay contact (normally open contact). The relay contact is fused with a 2 A fuse (slow-blow).



Setting the operating mode Eco/failsafe

► Set the jumper as required:

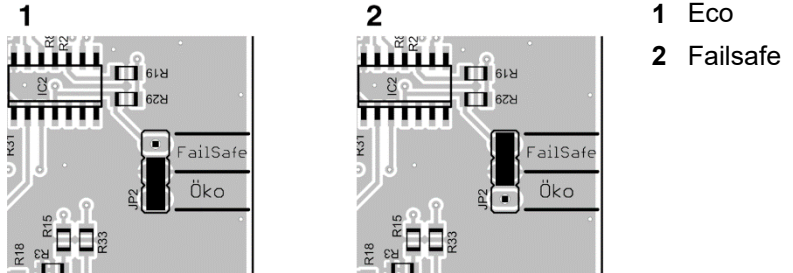

Fig. 11: Jumper

Table 3: Operating mode

Operating mode	Normal operation	Alarm condition
Eco	Relay de-energised	Relay energises
Failsafe	Relay energised	Relay de-energises



6.8 Commissioning the product

- The number of required black LAG containers has been determined.
- The black LAG containers have been mounted as per chapter 6.2, page 20.
- The pipes have been installed as per chapter 6.4, page 22.
- The test valve has been mounted as per chapter 6.5, page 24.
- The control unit has been installed as per chapter 6.6, page 24.
- The unit has been connected electrically as per chapter 6.7, page 26.
- The probe has been connected to the control unit.
- Output relay has been wired (if required).
- The unit has been connected to mains.
- The flat cable has been connected to the printed circuit board.
- The control unit has been closed.

If all requirements are met, you can fill leak detection fluid.

Filling

Double-walled containers (tanks) are delivered with leak detection fluid already filled into the interstitial space. The volume of leak detection fluid filled must be known and indicated on the nameplate of the tank. Only refill the specified leak detection fluid, mixed with water in the specified mixing ratio unless you have a certificate of the BAM (German Federal Institute for Materials Research and Testing) to the effect that the leak detection fluid you want to fill can be mixed with the leak detection fluid contained in the interstitial space.

1. For commissioning, open the test valve, place a collection receptacle below it and remove the probe from the black LAG container.
2. Remove the filling screw at the black LAG container and fill.
3. Do not close the test valve until leak detection fluid escapes.
4. Fill leak detection fluid up to the overflow opening of the liquid level mark.
5. Close the opening with the filling screw and refit the probe.



The vent hole \varnothing 5 mm at the neck of the black LAG container must remain open.

↙ The system is ready for operation.

6. Apply voltage via the on-site mains fuse.

↙ The green pilot lamp lights up.

7. Have the specialised company certify the installation, commissioning and test of the leak detector using the form in chapter 17.1, page 38.

7 Operation

LAG-14 ER monitors double-walled containers (tanks). In the case of a leak, leak detection fluid escapes and LAG-14 ER triggers an alarm. The operation of LAG-14 ER is limited to its regular monitoring:

- The green pilot lamp is on.
- The red alarm lamp is not on.
- The audible alarm is off.

7.1 Alarm condition

- ▶ In the case of an alarm, refill leak detection fluid (mixed with water in the specified mixing ratio) up to the indicated level. If the alarm repeats, there is a leak.
- ▶ The audible alarm can be muted by pressing the Acknowledge button. The red alarm lamp remains on.
- ▶ Immediately notify the installation company.



7.2 Function test

- ▶ Perform a function test once per year and after each repair and maintenance.

Simulation

1. Open the test valve and collect the escaping leak detection fluid using a suitable receptacle.
 - ↪ The leak detection fluid must escape at a flow rate of approx. 0.5 l/min.
 - ↪ As soon as the black LAG container is empty, the unit must trigger visual and audible alarms.
2. Close the test valve and refill the drained leak detection fluid into the black LAG container.
 - ↪ The alarm signals must switch off automatically.

At the probe

1. Remove the probe from the black LAG container.
 - ↪ The red alarm lamp must light up and the audible alarm must sound.
2. Refit the probe.
 - ↪ The alarm signals must immediately switch off.

At the control unit

- ▶ Press the test button.
 - ↪ The supply to the probe is interrupted.
 - ↪ The red alarm lamp must light up and the audible alarm must sound.

8 Maintenance

Leak detectors are safety equipment; if damaged, they may only be repaired by the manufacturer.

8.1 Maintenance times

It is recommended to close a maintenance agreement with a company specialised/certified according to the applicable water protection regulations.

Table 4: Maintenance times

When	Activity
Annually	▶ Perform a function test by simulating an alarm condition
At regular intervals	▶ Verify that the leak detector and its environment are always clean, accessible and easy to oversee

8.2 Maintenance activities

Replacing the mains fuse F1

- Mains voltage is interrupted and cannot be switched on.
 1. Open the control unit, see chapter 6.6, page 24.
 2. Remove the transparent cover from the mains fuse F1.
 3. Replace the mains fuse F1, see table 2, page 15.
 4. Snap the transparent cover onto the mains fuse F1.
 5. Connect the flat cable to the connector.
 6. Close the control unit, see chapter 6.6, page 24.
 7. Switch on the mains voltage.



Replacing the relay fuse F2

- ☑ Mains voltage is interrupted and cannot be switched on.
- 1. Open the control unit, see chapter 6.6, page 24.
- 2. Remove the transparent cover from the relay fuse F2.
- 3. Replace the mains fuse F2, see table 2, page 15.
- 4. Snap the transparent cover onto the relay fuse F2.
- 5. Connect the flat cable to the connector.
- 6. Close the control unit, see chapter 6.6, page 24.
- 7. Switch on the mains voltage.

9 Troubleshooting

Repairs may only be performed by specially trained, qualified staff.

Table 5: Troubleshooting

Problem	Possible reason	Repair
Green pilot lamp is not on	No mains voltage	▶ Supply mains voltage
	Mains fuse defective	▶ Replace the mains fuse
	Flat cable not connected to printed circuit board	▶ Connect the flat cable to the printed circuit board
Red alarm lamp is on	Alarm condition: leak	▶ Remove cause of alarm ▶ Refill leak detection fluid
	Probe not connected	▶ Connect probe
	Signal cable interrupted	▶ Check signal cable
Red alarm lamp is always on, even when the probe is submerged in leak detection fluid	Interruption in the signal cable, the probe or the control unit	▶ Check signal cable, probe and control unit
Pressing the Test button has no effect	Control unit defective	▶ Replace control unit
Removing the probe from the black LAG container has no effect	Short circuit in the probe, the signal cable or the control unit	▶ Check probe, signal cable and control unit
Other malfunctions	–	▶ Send the product to the manufacturer

10 Decommissioning, disposal

1. Switch off the supply voltage.



2. Dismount the leak detector LAG-14 ER (see chapter 6, page 17, reverse sequence of steps).
3. To protect the environment, this product must **not** be disposed of together with the normal household waste. Dispose of the product according to according to local directives and guidelines.

This product consists of materials that can be reused by recycling firms. The electronic inserts can be easily separated and the device consists of recyclable materials.

If you do not have the opportunity to dispose of the used device in accordance with environmental regulations, please contact us for possibilities to return it.



11 Spare parts and accessories

Part	Part no.
Leak detector LAG-14 ER + container	43410
LAG-14 ER control unit	40642
LAG container (black)	40731
LAG probe	40510
LAG mounting kit	40540
LAG mounting kit (additional container)	40541
Hose nipple G ³ / ₄ " (LAG container)	40558
Hose connection piece 1"	40557
Test valve KST	40555
EPDM hose 14 x 3 mm	40543
Leak detection fluid - concentrate	43645
Cable extension fitting KVA	40041
Mounting frame for control unit	43521
IP54 kit with cable gland M20	43416
Mains fuse F1 (T 100 mA H; 1.5 kA)	960127 0100
Relay fuse (T 2 A)	960127 2000



12 Leak detection fluids for leak detector

The leak detection fluids listed have been tested by the German "Bundesanstalt für Materialforschung und -prüfung" BAM (Federal Institute for Materials Research and Testing) and may be used for liquid-based leak detectors. They have been tested for their fungicidal effect and their compatibility with the flammable liquids fuel oil EL, diesel fuel and carburettor fuel. Other leak detection fluids may no longer be used in the interstitial spaces of double-walled containers (tanks).

Company	Product	BAM reference
Clariant SE Am Unisys Park 1 65843 Sulzbach	Antifrogen N leak detection fluid Leckanzeige-Clariant	1.3/9790 – 5.1/3436 1.3/10723-N1 - 5.1/3833-N1

The leak detector LAG-14 ER is suitable for the leak detection fluids listed below.

The leak detector LAG-14 ER can continue to be used as a spare device in existing systems with already approved leak detection fluids.

13 Warranty

See our terms and conditions at www.afriso.com or your purchase contract for information on warranty.

14 Copyright

The manufacturer retains the copyright to these operating instructions. These operating instructions may not be reprinted, translated, copied in part or in whole without prior written consent.

We reserve the right to technical modifications with reference to the specifications and illustrations in this manual.

15 Customer satisfaction

Customer satisfaction is our prime objective. Please get in touch with us if you have any questions, suggestions or problems concerning your product.

16 Addresses

The addresses of our worldwide representations and offices can be found on the Internet at www.afriso.com.



17 Appendix

17.1 Certification of specialised company (according to applicable water regulations)

I hereby confirm the installation of the leak detector and performance of a function test of the leak detector according to these operating instructions:

Tank: _____

according to or as per standard: _____

Manufact. number: _____

Volume in litres: _____

Leak detection fluid designation: _____

Volume in litres: _____ (in interstitial space)

Volume in litres: _____

Owner/Operator + location of system:

Specialised company:

Date, stamp + signature: _____



17.2 Approval documents

ZERTIFIKAT ◆ CERTIFICATE ◆ 認 証 証 書 ◆ СЕРТИФИКАТ ◆ CERTIFICADO ◆ CERTIFICAT



Product Service

EG-Baumusterprüfbescheinigung

Nr. EX5 11 02 15639 011

Zertifikatsinhaber: AFRISO-EURO-INDEX GmbHLindenstr. 20
74363 Güglingen
DEUTSCHLAND**Produkt:** Leckanzeigen
Gerätegruppe II, Kategorie 1**Modell(e):**  Leckanzeigergerät
LAG-14ER**Kenndaten:** Gerätegruppe II, Kategorie (1) G,
Zündschutzart [Ex ia] IIC bzw. [Ex ia] IIB

Kennzeichnung Ex II (1) G

Typ:	LAG-14 ER
Abmessung	
Gehäuse:	100 x 188 x 65 mm
Gewicht:	0,4 kg
Nennleistung:	5 VA
Netzsicherung:	M 32 mA Ex
Relaisstromkreis	
Klemme 2:	250 V, 3 A, $\cos \phi \leq 0,7$
Relaissicherung:	T 2 A
Geberstromkreis:	ia
Höchstwerte:	U _o = 16,8 V, I _k = 57 mA, P = 240 mW, Kennlinie linear
Höchstzul. äuß.	
Kapazität:	180 nF für IIC, 675 nF für IIB
Höchstzul. äuß.	
Induktivität:	1 mH für IIC, 8 mH für IIB
Innere wirksame Kapazitäten und Induktivitäten sind vernachlässigbar.	

Diese EG-Baumusterprüfbescheinigung bestätigt die Übereinstimmung des bezeichneten Produktes mit den einschlägigen Vorschriften gemäß Anhang III der Richtlinie des Rates Nr. 94/9/EG für Geräte und Schutzsysteme zur bestimmungsgemäßen Verwendung in explosionsgefährdeten Bereichen (ATEX). Prüfgrundlage ist ausschließlich das zur Prüfung und Zertifizierung vorgestellte Prüfmuster sowie dessen technische Dokumentation. Umseitige Hinweise sind zu beachten.

Prüfbericht Nr.: 71379414**Datum,** 2011-02-23

(Andreas Pfeil)

TÜV SÜD Product Service GmbH ist benannte Stelle gemäß der Richtlinie des Rates Nr. 94/9/EG für Geräte und Schutzsysteme zur bestimmungsgemäßen Verwendung in explosionsgefährdeten Bereichen mit der Kennnummer 0123.

Seite 1 von 1



TÜV SÜD Product Service GmbH · Zertifizierstelle · Ridlerstraße 65 · 80339 München · Germany

TUV®



17.3 EU Declaration of Conformity



Technik für Umweltschutz

Messen. Regeln. Überwachen.

EU – Konformitätserklärung

EU-Declaration of Conformity / Déclaration EU de conformité
Declaración de conformidad CE / Declaração de conformidade CE



Formblatt
FB 27 - 03

Name und Anschrift des Herstellers: AFRISO-EURO-INDEX GmbH, Lindenstr. 20, 74363 Güglingen
Manufacturer / Fabricant / Fabricante / Nome e endereço do fabricante:

Erzeugnis: Leckanzeigergerät

Product / Produit / Producto / Produto:

Typenbezeichnung: LAG 14ER

Type / Type / Tipo / Tipo:

Betriebsdaten: 230V, 50Hz, 5VA, IP30

Techn. Details:

Caractéristiques / Características / Detalhes técnicos:

Wir erklären in alleiniger Verantwortung, dass das bezeichnete Erzeugnis mit den Vorschriften folgender Europäischer Richtlinien übereinstimmt:

The above mentioned product meets the requirements of the following European Directives

Le produit mentionné est conforme aux prescriptions des Directives Européennes suivantes

El producto indicado cumple con las prescripciones de las Directivas Europeas siguientes

O produto indicado cumpre com as prescrições das seguintes Diretivas Europeias:

Elektromagnetische Verträglichkeit (2014/30/EU)

Directive Electromagnetic Compatibility / Directive compatibilité électromagnétique / Directiva compatibilidad electromagnética / Diretiva sobre compatibilidade eletromagnética

- DIN EN 60730-1:2011

Niederspannungsrichtlinie (2014/35/EU)

Low Voltage Directive / Directive basse tension / Directiva baja tensión / Diretiva sobre baixa tensão

- DIN EN 60730-1:2011

Explosionsschutz- Richtlinie (2014/34/EU)

ATEX Directive / Directive ATEX / Directiva ATEX / Diretiva ATEX

- DIN EN 60079-0:2012, EN 60079-0:2012/A11:2013

- DIN EN 60079-11:2012

- EG-Baumusterbescheinigung-Nr.: EX5 11 02 15639 011

- TÜV SÜD Product Service GmbH, Ridlestr. 65, 80339 München, Kennnummer 0123

Bauprodukte Verordnung (EU) Nr. 305/2011 + Nr. 574/2014

Construction Products Directive / Examen CE de Type / Certificado CE de tipo / Examo do tipo construtivo

- EN 13160-1:2003, EN 13160-3:2003

RoHS-Richtlinie (2011/65/EU)

RoHS Directive / Directive RoHS / Directiva RoHS / Diretiva RoHS

Unterzeichner:

Dr. Aldinger, Geschäftsführer Technik

Signed / Signataire / Firmante / Assinado por:

Technical Director / Diretor Técnico

20.4.2016

Datum / Date / Fecha / Data



AFRISO

AFRISO-EURO-INDEX GmbH
Lindenstr. 20 • 74363 Güglingen
Tel. +49 7141 900-0 • Fax +49 7141 900-100
www.afriso.de

Unterschrift / Signature / Firma / Assinatura

Version: 3 / Index: 0

AFRISO-EURO-INDEX GmbH

D-74363 Güglingen

Seite: 1 von 1

983000 50004 0613



17.4 Declaration of Performance (DoP)



Technik für Umweltschutz

Messen. Regeln. Überwachen.



LEISTUNGSERKLÄRUNG (DoP)

Nr.: LAG14-EU-BauPVO-DE-2014

nach Verordnung (EU) Nr. 305/2011 DES EUROPÄISCHEN PARLAMENTS UND DES RATES vom 9. März 2011 zur Festlegung harmonisierter Bedingungen für die Vermarktung von Bauprodukten und zur Aufhebung der Richtlinie 89/106/EWG des Rates

1. Eindeutiger Kenncode des Produkttyps:

Leckanzeiger Typ LAG 14 ER
Flüssigkeitssysteme für Tanks

2. Verwendungszweck:

Leckanzeigesystem der Klasse II für den Einsatz in doppelwandigen Tanks für wassergefährdende Flüssigkeiten

3. Hersteller:



AFRISO

AFRISO-EURO-INDEX GmbH

Lindenstraße 20, 74363 Güglingen

Tel.-Nr.: +49 7135 102-0 Fax: +49 7135 102 212

e-Mail: info@afriso.de www.afriso.de

4. Bevollmächtigter: N.A.

5. System zur Bewertung und Überprüfung der Leistungsbeständigkeit:
System 3

6. Harmonisierte Norm: EN 13160-1:2003, EN 13160-3:2003

Notifizierte Stelle:

TÜV Nord Systems GmbH & Co KG, Competence Center Tankanlagen, Große Bahnstraße 31,
22525 Hamburg, Deutschland
Kennnummer des notifizierten Prüflabors: 0045

7. Erklärung Leistungen:

Wesentliche Merkmale	Leistung
Erkennung von Pegeländerungen	bestanden
Anforderungen an die Software	bestanden
Dauerhaftigkeit gegen Temperatur	bestanden
Dauerhaftigkeit gegen Chemikalienangriff	bestanden
Dauerhaftigkeit gegen mikrobiellen Bewuchs	bestanden

8. Unterzeichnet für den Hersteller und im Namen des Herstellers von:

Dr. U. Aldinger
Güglingen, 17.07.2014

9930005 30004 06/13



17.5 CE Marking



**AFRISO-EURO-INDEX GmbH, Lindenstr. 20
74363 Güglingen, Germany**

14

EN 13160:2003

**Leckanzeigesystem der Klasse II
Typ: LAG 14 ER**

Für den Einsatz in doppelwandigen Tanks für wassergefährdende Flüssigkeiten.

Installation nach Betriebsanleitung 854.000.0153

Betriebsweise: elektrischer Sensor zur Überwachung des Pegelstands der leitfähigen Leckanzeigeflüssigkeit im Leckanzeigebehälter

Leckanzeigeflüssigkeit: Antifrogen N
Temperaturbegrenzung: -20°C bis +50°C
Schalt-/Rückstellzeit Sensor: < 1 s