

Standard Bourdon tube pressure gauges

EN 837-1

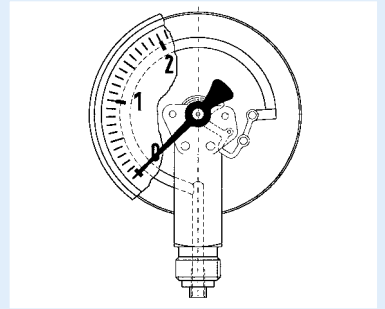

- For pneumatic and heating system applications
- Design as per EN 837-1
- Accuracy class 1.6
- Corrosion-resistant, highly impact-resistant plastic housing
- Many customised versions available



1

Application For gaseous and liquid media which are not highly viscous, do not crystallise and do not attack copper alloys.

! For measuring gas or vapour, these gauges must be used in accordance with the table "Selection Criteria as per EN 837-2" (see appendix)!

Technical specifications

Type

D 1

Nominal size

40 – 50 – 63 – 80 – 100

Accuracy class (EN 837-1/6)

1.6

Ranges (EN 837-1/5)

-1/0 to -1/+15 bar
0/0.6 to 0/400 bar

Application area

Static load: $\frac{3}{4}$ x full scale value
Dynamic load: $\frac{2}{3}$ x full scale value
Short-term: full scale value

Operating temperature range

Medium: $T_{\max} = +60\text{ }^{\circ}\text{C}$
Ambient: $T_{\min} = -20\text{ }^{\circ}\text{C}$
 $T_{\max} = +60\text{ }^{\circ}\text{C}$

Temperature performance

Indication error when the temperature of the measuring system deviates from the normal temperature of 20 °C:
rising temperature approx. $\pm 0.4\text{ } \%/10\text{ K}$
falling temperature approx. $\pm 0.4\text{ } \%/10\text{ K}$
of full scale value

Degree of protection

IP 32 (EN 60529)

Standard version

Connection

Brass, bottom or centre back
NG 40 G $\frac{1}{8}$ B – SW 12
NG 50-63 G $\frac{1}{4}$ B – SW 14
NG 80-100 bottom G $\frac{1}{2}$ B – spanner size SW 22
NG 80-100 centre back G $\frac{1}{4}$ B – spanner size SW 14
(EN 837-1/7.3)

Measuring element

Bourdon tube, copper alloy
 $\leq 60\text{ bar}$ "C" type tube
 $> 60\text{ bar}$ helical tube

Movement

Brass

Dial

Plastic, white
Dial marking black

Pointer

Plastic, black

Housing

Black ABS, highly impact-resistant and corrosion-resistant

Window

Clip-in plastic, NG 80-100 with adjustable red reference pointer

Options

- Damping screw
- Reference pointer
- Special scales
- Other process connections

i

See the catalogue DOMESTIC TECHNOLOGY for special heating and sanitary versions. See page 297 for prices.

Standard Bourdon tube pressure gauges

Type D 1 – NG 40/50/63/80/100

1 Housing types and dimensions

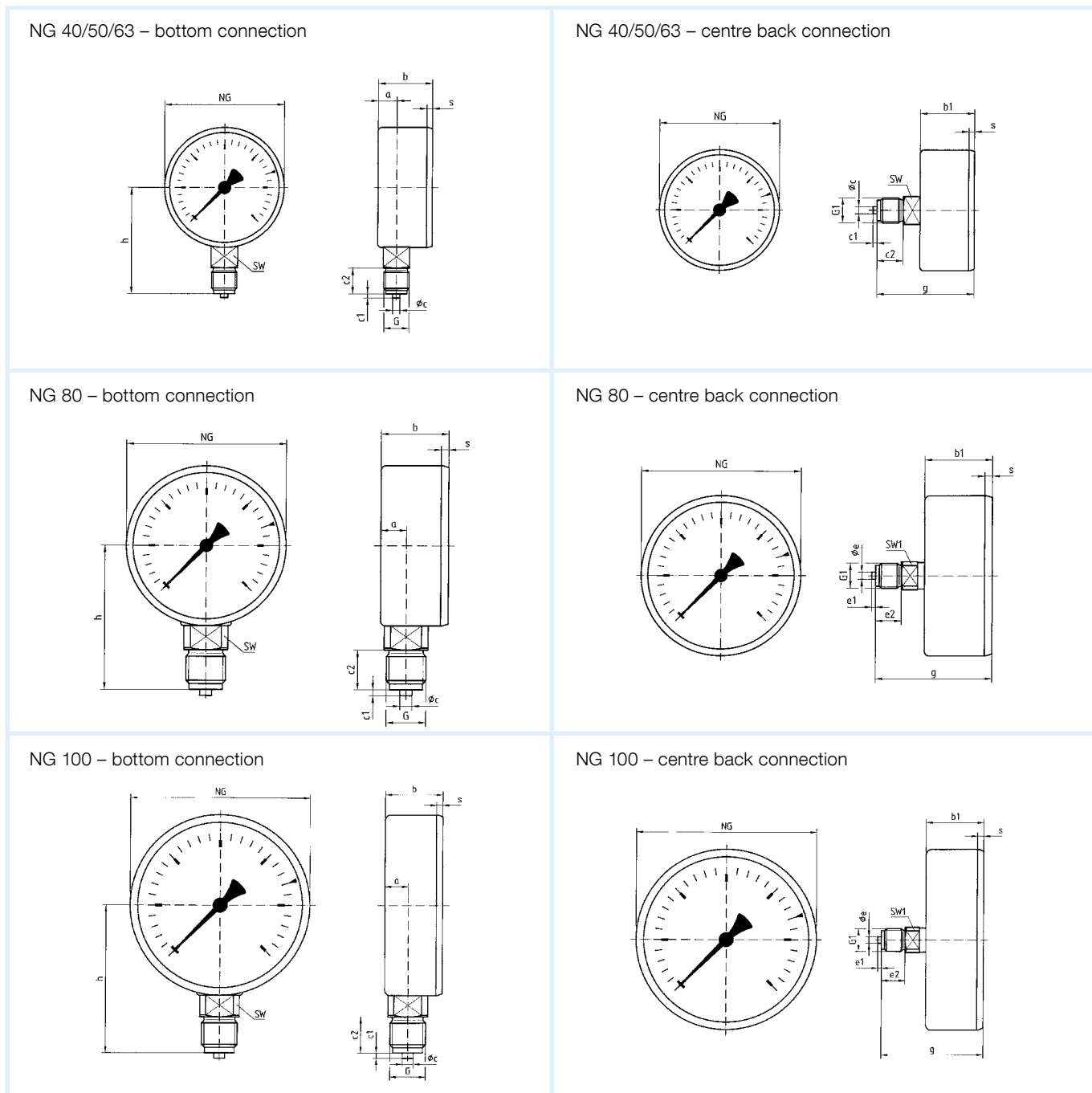

Dimensions (mm)

Nominal size (NG)	a	b	b1	Øc	c1	c2	Øe	e1	e2	g	G	G1	h	s	SW	Spanner size SW1
40	9.5	25	25	4	2	10	-	-	-	41.5	G1/8B	G1/8B	36	3	12	-
50	10.3	26.8	27.1	5	2	13	-	-	-	47.1	G1/4B	G1/4B	45	3.8	14	-
63	9.8	29.7	30.4	5	2	13	-	-	-	50.4	G1/4B	G1/4B	51.5	3.7	14	-
80	12.8	32.8	32.8	6	3	20	5	2	13	55.8	G1/2B	G1/4B	72	2.8	22	14
100	15.5	34.5	32	6	3	20	5	2	13	55	G1/2B	G1/4B	82	3.5	22	14