

Diaphragm seals MD 50/51 for screwed pipe connections (food)



2



- All materials FDA-listed
- Suitable for SIP/CIP
- No dead space
- Various standards available

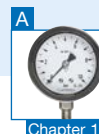

Application Diaphragm seals MD 50/51 with food law compliant screwed pipe connection for hygienic process separation of pressure measuring and control units in pipes or tanks. For mounting to Bourdon tube pressure gauges, pressure transducers and pressure switches. For installation in hygienic processes without dead spaces.

- Food and beverages industry
- Dairies
- Beverage machines
- Breweries

Description All materials used are FDA-listed. The chemical seal and the measuring instrument are welded together, resulting in an inseparable single, shock- and vibration-resistant unit that does not require additional external protection. The chemical seals are available with various nominal diameters; due to their compact design, they are suitable for a wide range of applications.

Technical specifications

Type
MD 50 and 51

Process connections
MD 50: DIN 11851/11887 DN 25 to DN 65
MD 51: SMS 1147 1" to 2½"

Material
Stainless steel 316 L, FDA-listed

Surface roughness
Ra ≤ 0.8 µm

Pressure transmission liquid
Paraffin oil (FM 09), FDA-listed

Pressure ranges
0.6 bar to 40 bar

- Can be mounted to**
- Bourdon tube pressure gauges NG 50, 63, 80, 100, 160
 - Pressure transducers (DMU)
 - Pressure switches (DS)

- Options**
- Other designs (Südmo, Guth)
 - Other materials
 - Electropolished
 - Cooling element
 - Capillary
 - Other pressure transmission liquids
 - Accessories such as union nuts and seals
 - Other process connections:
 - MD 52-1: DIN 11864-1 GS or ÜM, design A/B, DN 25/80, H3
DIN 11853-1 GS or ÜM, DN 25/80, H3
 - MD 52-2: DIN 11864-2 NF or BF, design A/B, DN 25/80, H3
DIN 11853-2 NF or BF, DN 25/80, H3
 - MD 52-3: DIN 11864-3 NKS or BKS, design A/B, DN 25/80, H3
DIN 11853-3 NKS or BKS, DN 25/80, H3
 - MD 53: APV-RJT 1" to 3"
 - MD 54: IDF 1" to 3"
 - MD 55: APV-ISS 1" to 3"



See page 180 for prices.

Diaphragm seals MD 50/51

Types and dimensions (mm)

Tapered socket DIN 11851 type D/
DIN 11887 type B with grooved union nut DIN 11851 type F

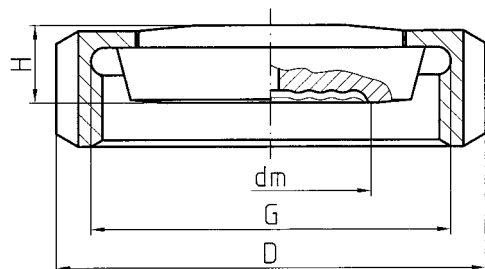

Type	DN	PN	dm	G	D	H
MD 50, DIN 11851	25	40	23.5	Rd52x1/6	63	14
	32	40	28	Rd58x1/6	70	14
	40	40	36	Rd65x1/6	78	14
	50	25	48	Rd78x1/6	92	15
	65	25	48	Rd95x1/6	112	16

Threaded socket DIN 11851 type C/DIN 11887 type A

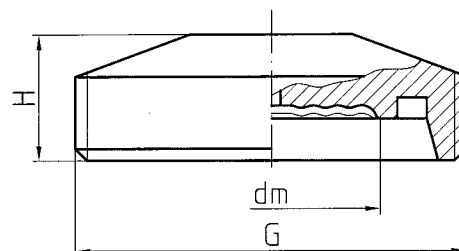

Type	DN	PN	dm	G	H
MD 50, DIN 11851	25	40	23.5	Rd52x1/6	21
	32	40	28	Rd58x1/6	21
	40	40	36	Rd65x1/6	21
	50	25	48	Rd78x1/6	21
	65	25	-	Rd95x1/6	-

Socket and union nut SMS 1147

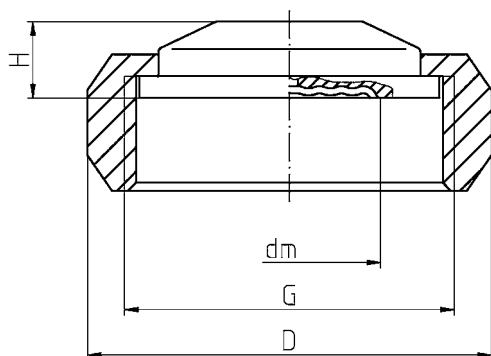

Type	DN	PN	dm	G	D	H
MD 51, SMS stand- ard	1½"	40	36	Rd60x1/6	74	14
	2"	40	48	Rd70x1/6	84	14
	2½"	25	48	Rd85x1/6	100	14

Threaded socket SMS 1147

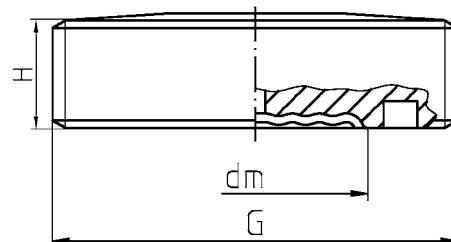

Type	DN	PN	dm	G	H
MD 51, SMS stand- ard	1½"	40	36	Rd60x1/6	17
	2"	40	48	Rd70x1/6	17
	2½"	25	48	Rd85x1/6	17